

MVSY-100 series

SOLENOID VALVE

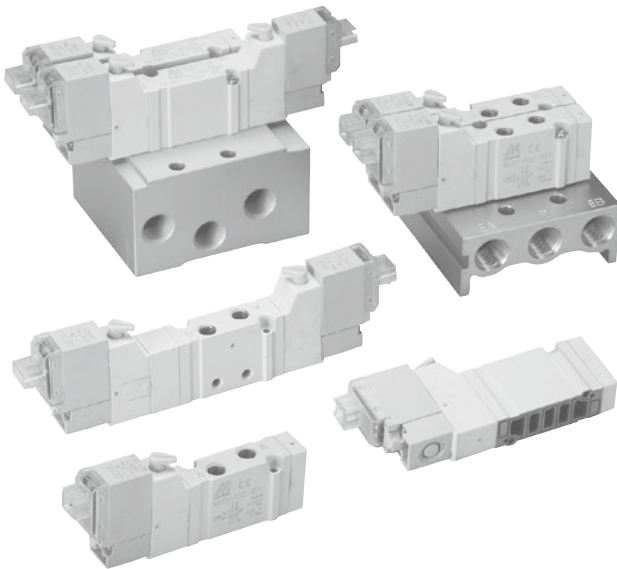

mindman



Specification

Model	4E1	4E2	4E2 C.P.R
Bore No.	M5		
Port size	M5×0.8		
No. of port	5		
No. of position	2	3	
Medium	Air		
Operating perssure range	0.2~0.7 MPa		
Proof pressure	1 MPa		
Effective orifice	Body ported	4.5 mm ²	
	Manifold	4.5 mm ²	4.5 / 5 / 4.5 mm ²
Reponse time	12 ms	15 ms	
Ambient temperature	+5~+50°C		
Max. operating frequency	5 Hz		
Voltage	AC110V, 220V (50/60)Hz, DC24/12/6V		
Power consumption	AC=1.6/2.5VA, DC6=1.2W, DC12/24=0.55W		
Available voltage range	±10%		
Insulation class	B class		
Weight	30 g	44 g	59 g

Caution

- Don't continuous energizing for about 2 hours or more.
- The total energizing time of a day don't exceeds the total non-energizing time even if it is intermittent energizing.

Order example of valve

MVSY – 100M – 4E2C – AC110 – LJ1

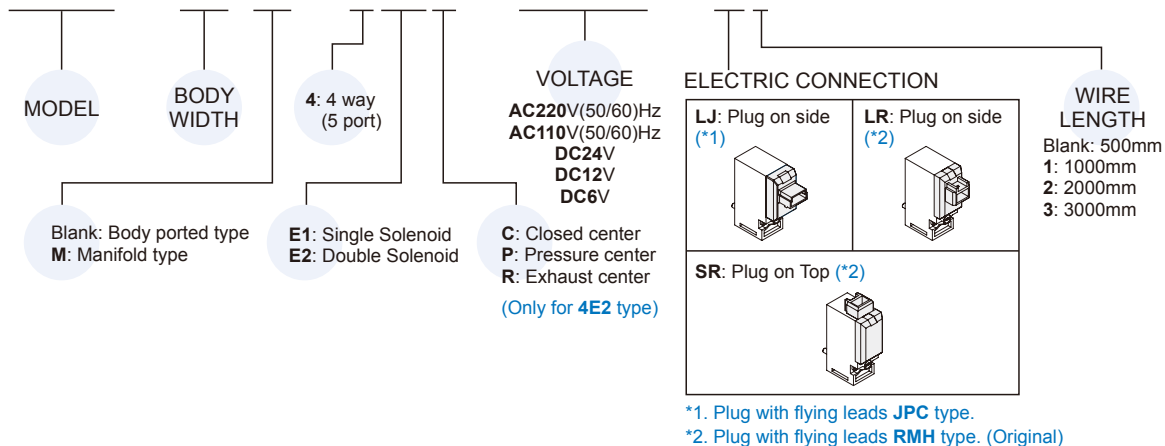

Order example of manifold

MVSY – 100M – 5B3 – G

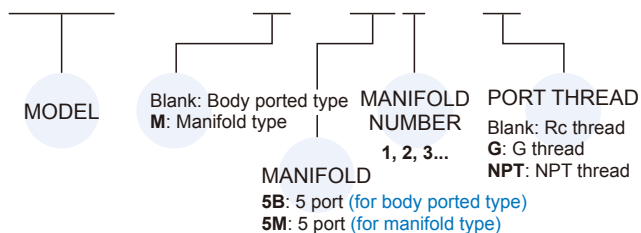

Order example of wire

* Use the same wire with MVDY.

MVDY – 100 – WA2J2

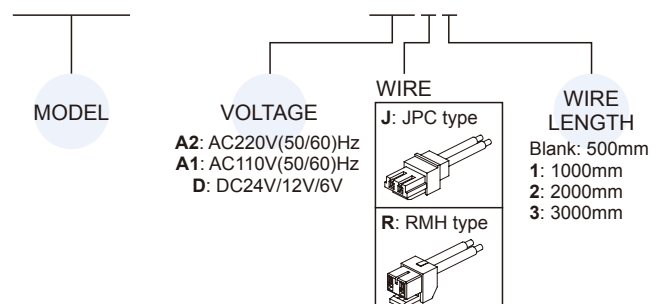

MVSY-100 Dimensions

SOLENOID VALVE



MVSY-100-4E1

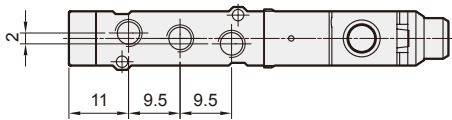
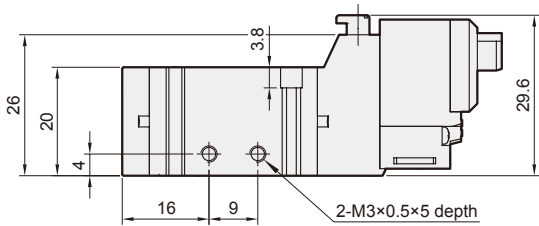
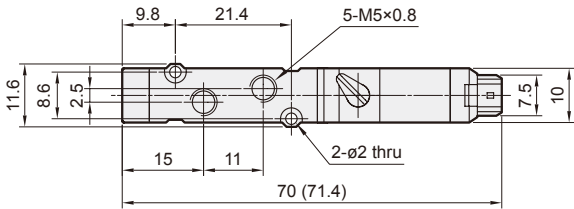
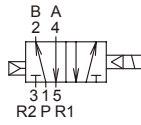

MVSY-100-4E2

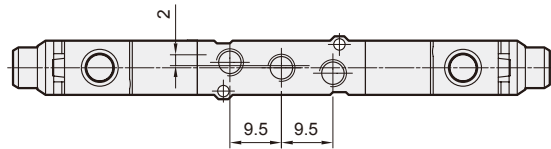
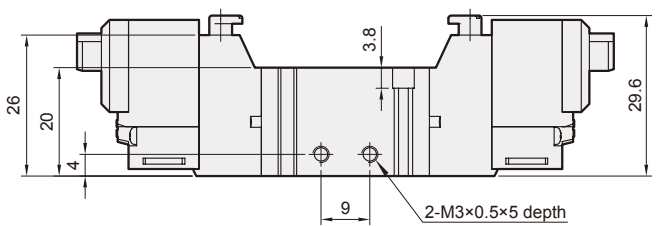
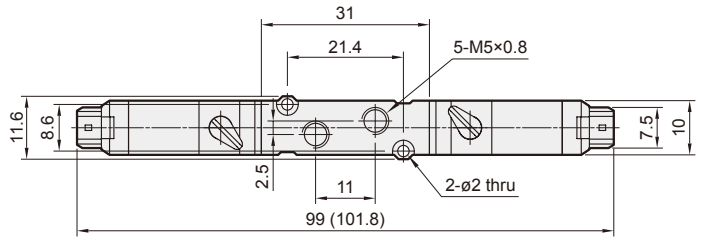
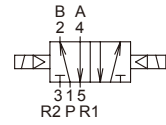

MVSY-100-4E2C.PR

MVSY-100-4E2C

MVSY-100-4E2P

MVSY-100-4E2R

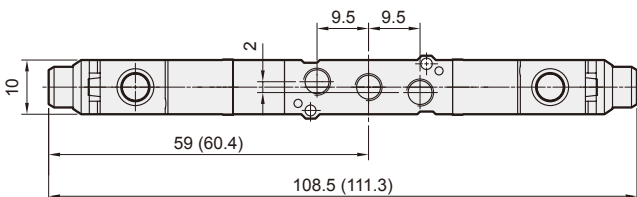
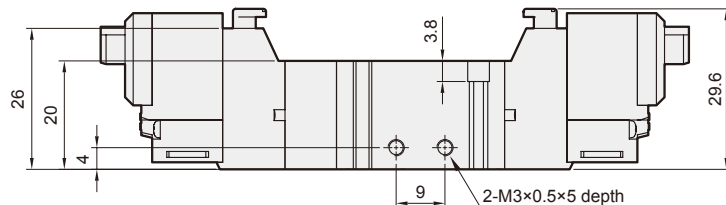
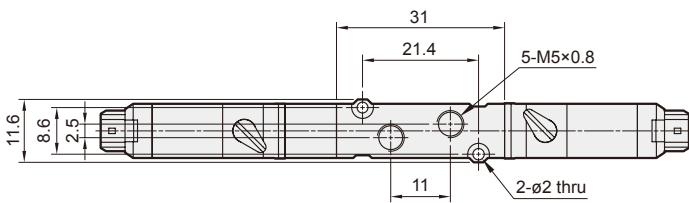
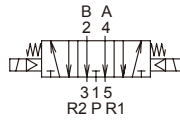
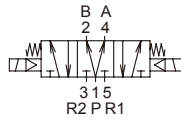
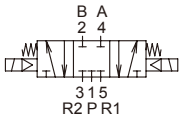

Flow features

MVSY-100-4E1/4E2

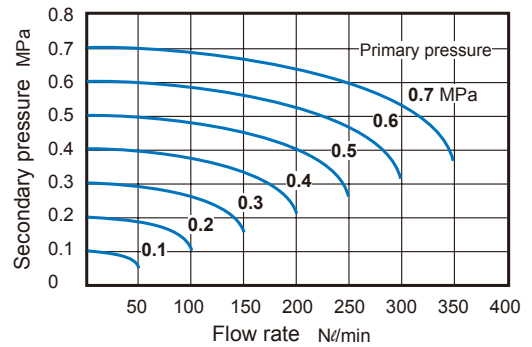

() : Dimension for LJ plug type.

MVSY-100 Manifold

SOLENOID VALVE



MVSY-100-5B*

5 port (for body ported type)

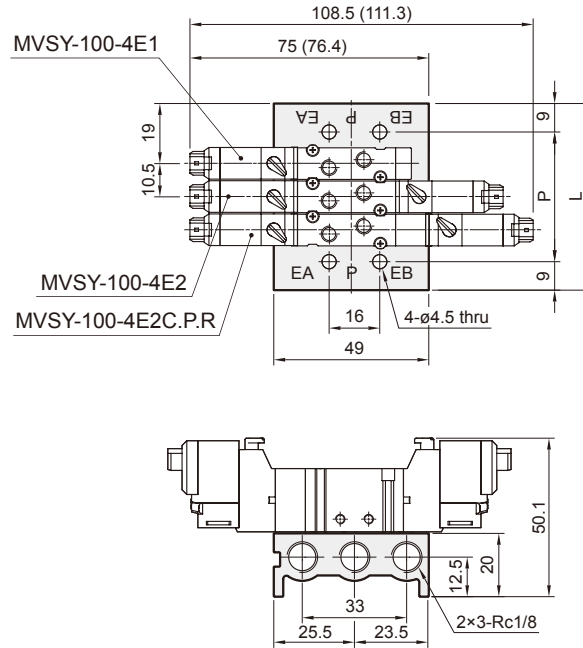

No. of stations	P	L
2	30.5	48.5
3	41	59
4	51.5	69.5
5	62	80
6	72.5	90.5
7	83	101
8	93.5	111.5
9	104	122
10	114.5	132.5

MVSY-100M-5M*

5 port (for manifold type)

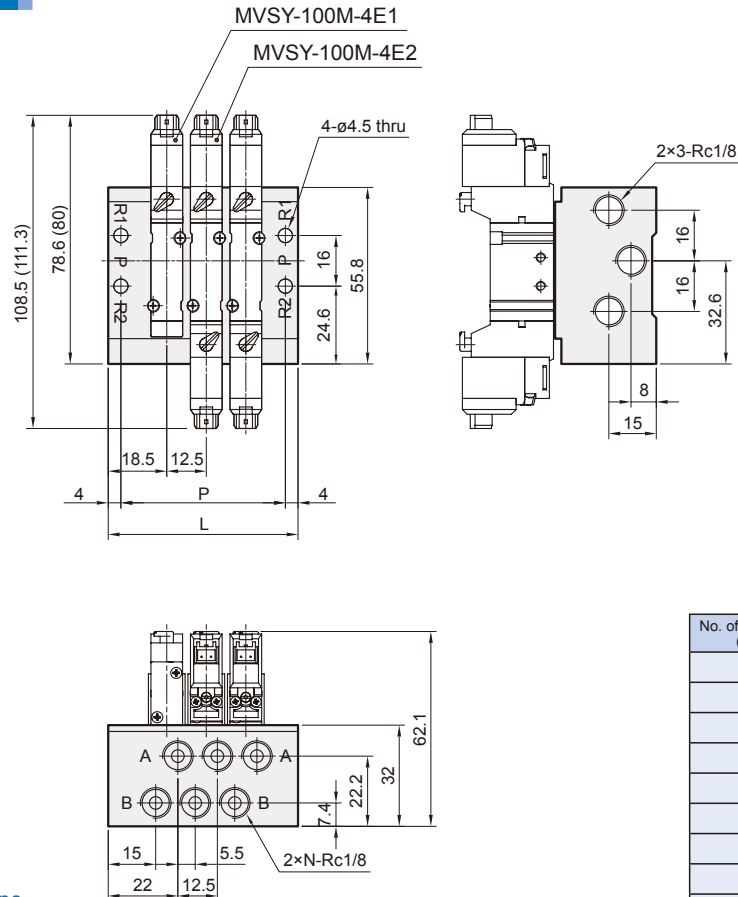

No. of stations (N)	P	L
2	39.5	47.5
3	52	60
4	64.5	72.5
5	77	85
6	89.5	97.5
7	102	110
8	114.5	122.5
9	127	135
10	139.5	147.5

() : Dimension for LJ plug type.

MVSY-100 Mounting bracket

SOLENOID VALVE



Order example of bracket

MVSY – 100 – 1A

MODEL

MOUNTING BRACKET

1A
2A

MVSY-100-1A

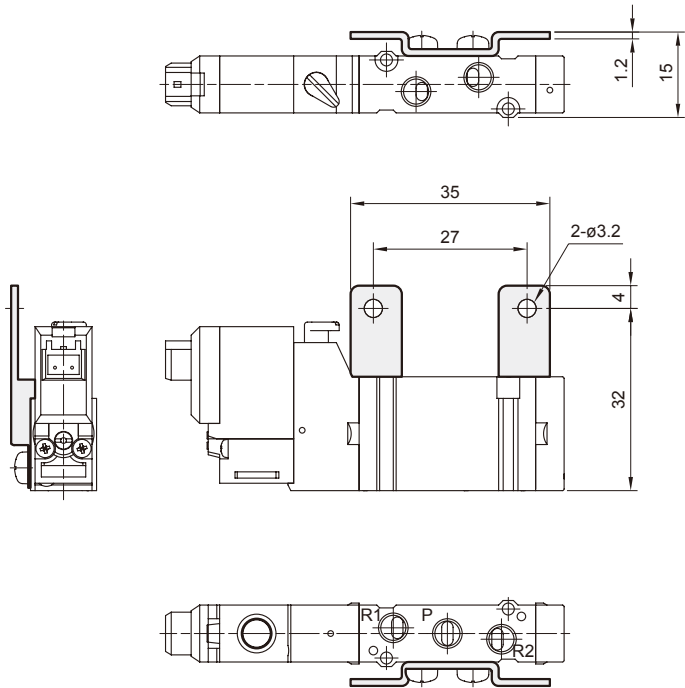
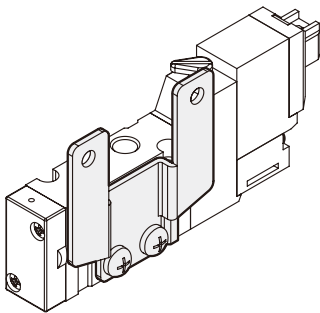

MVSY-100-2A

