

GENERAL FEATURES

- **TORK series S8110 diaphragm drain solenoid valves are 2/2 way normally closed and pilot operated**
- **The standby and drainage periods can be regulated by the timer on itself. It is attached to the part of the valve which is drained. The valve is opened to drain on time which the timer is programmed.**
- **On request; normally open types**
- **Suitable for non-aggressive liquids (water, light oil (2E) etc...), gaseous fluids (air, inert gases etc...)**
- Working Temperature: -10°C / +80°C
- Not suitable for use with dangerous fluids listed in Group 1
- **Minimum operating differential pressure 0,5 bar**
- High reliability, quality and performance; long life, corrosion resistance
- Wide pressure ratings, range of flow rate and orifice options
- Ideal for the automatic control of media in a wide range of applications.
- TORK solenoid valves satisfy relevant 97/23/EC, Pressure Equipment Directive (PED) and 2006/95/EEC Low Voltage Directive (LVD).
- Some applications; separator main drainage
- Coils interchangeable
- Flow factor Kv of each valve is indicated, so that the flow Q can be calculated as a function of pressure
- Solenoid valves must be used with filtered fluids.
- Solenoid valve can be mounted in any position without affecting operation; vertical with coil upwards preferred.
- Standard pipe connection is G (BSP) (ISO 228-1) and on request; other pipe connections are available (NPT (ANSI 1.20.3))

ELECTRICAL CHARACTERISTICS

- Continuous Duty : ED %100
- Coil Insulation Class : H (180°C)
- Coil Impregnation : Polyester Fiber Glass
- Coil Encapsulation Material : Fiber Glass Reinforced
- Ambient Temperature : from -10°C; +60°C
- Protection Degree : IP 65 (EN 60529) with coil duly fitted with the plug connector
- Electric Plug Connection : DIN 46340 3-poles connectors (DIN 43650)
- Connector Specification : ISO 4400 / EN 175301-803, Form A, Spade plug (Cable Ø 6-8 mm)
- Electrical Safety : IEC 335
- Standard Voltages : For AC 12V, 24V, 48V, 110V, 230V
For DC 12V, 24V, 48V, 110 V

- Other voltages on request;
- Voltage Tolerances : For AC %-15; %+10, For DC %-5; %+10
- Frequency : 50 Hz , other frequencies on request; (60 Hz)
- On request; connector with LED
- Specify coil voltage with order

MATERIALS IN CONTACT WITH FLUID

- Body : Brass
- Internal Parts : Stainless Steel
- Sealing : NBR
- Shading Ring : Copper
- Seats : Brass
- Core Tube : Stainless Steel
- Springs : Stainless Steel
- On request; sealing can be FPM (VITON), EPDM

TECHNICAL FEATURES

- Max Viscosity: 5°E (-37cSt or mm²/s)
- Response Time: Opening Time: 400 ms to ~ 1600 ms, Closing Time : 1000 ms to ~ 2000 ms
- Maximum Allowable Pressure: 25 bar
- Fluid Temperature for FPM (VITON) from -10°C; +160°C, for EPDM from -10°C; +140°C

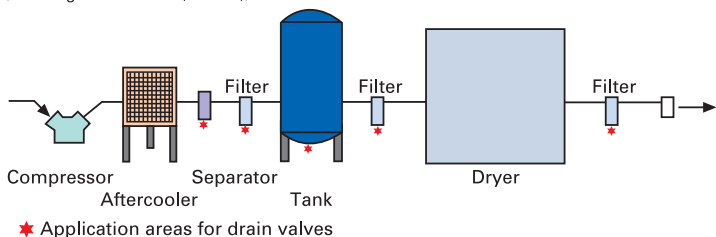

Normally Closed

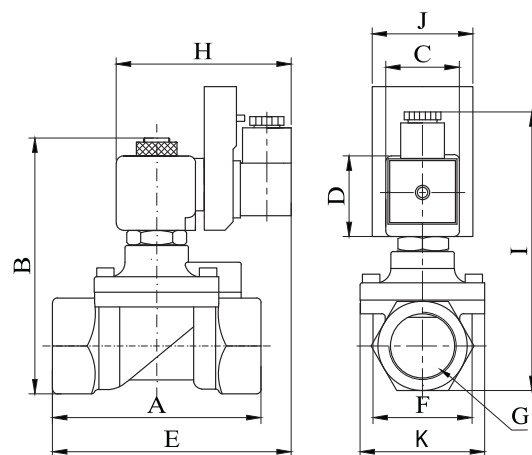
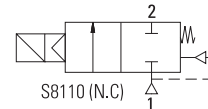

Dimensions (mm)

	G	A	B	C	D	E	F	K	H	I	J
3/8"	74	97	32	45	109.3	37.5	52	76	108	42.3	
1/2"	79	100	32	45	110	39.8	52	76	110	42.3	
3/4"	79	107.3	32	45	112	41.5	52	76	118	42.3	
1"	85	115	32	45	115	42.5	52	76	124	42.3	

Valve Type / Order no	Connection Size	Orifice size	Pressure		KV	Fluid Temperature		Seal	Weight
			min	max		min	max		
S8110	G	mm	bar	bar	lt/min	°C			(kg)
S 8 1 1 0 . 0 2	3/8"	12.5	0.5	16	48	-10	80	NBR	0.68
S 8 1 1 0 . 0 3	1/2"	14.5	0.5	16	70	-10	80	NBR	0.71
S 8 1 1 0 . 0 4	3/4"	17	0.5	16	85	-10	80	NBR	0.8
S 8 1 1 0 . 0 5	1"	17	0.5	16	90	-10	80	NBR	0.97

Useful Informations

1 bar:14,5 PSI:10 mH₂O:10 N/cm²:1 kg/cm²:100000 Pa , 1 PSI:69 mbar,1 m³/h:4.405 GPM:16,7 L/d 1 Gallon / minute:0,227 m³/h, 0°C:89,6 F
Sealings:NBR:Nitrile-Butylene Elastomer , FPM (VITON):Fluoro-Carbon Elastomer, EPDM:Ethylene-Propylene Elastomer